

CHEVROLET LUV SERIES 5



Chevrolet's LUV competes in the growing import pickup market • Built by Isuzu Motors Ltd., an internationally known Japanese car and truck manufacturer • Sold and serviced by most Chevrolet dealers in the U.S.A.

Small size offers good maneuverability, parking ease, agility in city driving • Load capacity is good, overall operating cost is low • Ideal personal-use vehicle • 6' pickup box length • Versatile and fun to drive.

CHEVROLET LUV VALUE FEATURES

New for Series 5



Impressive gas mileage • In EPA mileage tests, LUV is rated at 23 miles per gallon in the city — equipped with a manual transmission — and 33 miles per gallon on the highway. *Remember:* these mileage figures are *estimates* as published in the EPA Buyer's Guide. Actual mileage will vary depending on the type of driving, driving habits, truck's condition, and available equipment. The chart below details the improved EPA mileage ratings of the new LUV.

EPA MILEAGE TEST RESULTS

		1975		1976	
	Transmission	City	Hwy	City	Hwy
49-State	Manual	19	27	23	33
49-State	Automatic			21	29
California	Manual	18	30	21	32
California	Automatic			19	28

New 3-speed automatic transmission • Turbo Hydra-matic model THM-200 • T-handle selector is pedestal-mounted on the floor.

New engine • 4-cylinder in-line engine is rated at 80 horsepower (SAE net) • Single overhead camshaft has dual rocker arms with intake and exhaust efficiency assured by cross-flow-designed ports • Combustion chambers are hemispherical for efficient fuel burning • To save weight, the cylinder head is cast aluminum • For strength, 5 tri-metal steel-backed main bearings support the forged steel crankshaft • Fuel requirement is non-leaded fuel • California units include the catalytic converter.

New smooth ride • New E78-14B bias-belted passenger car type tires mounted on one-inch wider rims • Cab and body mounts and rear suspension bushings and shackles have been redesigned • Vehicle trim attitude has been improved by redesigning the rear springs • LUV's rear springs consist of four semi-elliptical main leaves • Two-stage design, including an auxiliary leaf, helps compensate for increased cargo weights • To further soak up the jolts, LUV has torsion bar independent front suspension • New full-foam cushioned seats.

New standard front disc brakes • Front brakes are the single-cylinder floating caliper type • Power vacuum assist is standard.

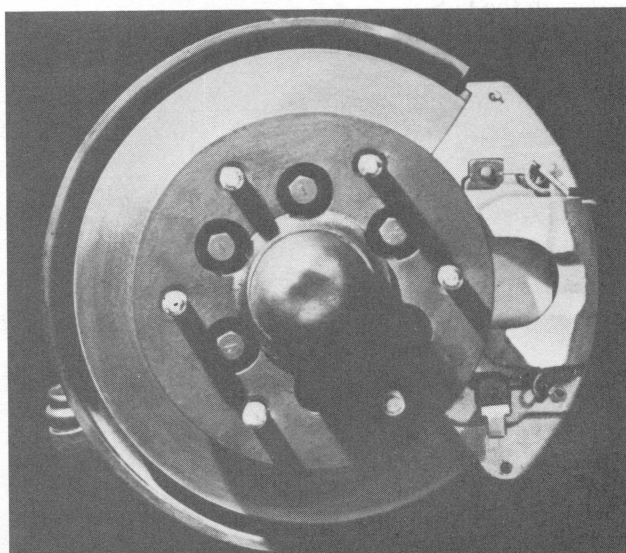

CHEVROLET LUV ENGINE AND CHASSIS FEATURES

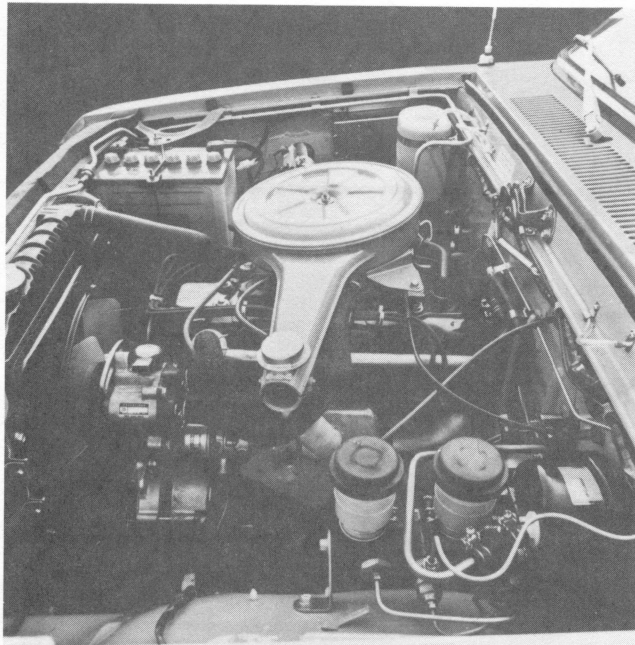

Engine develops 80 hp from 110.8-cubic-inch displacement • Four cylinders in-line • Overhead camshaft • Water-cooled • Modern design: aluminum cylinder head, cast iron block, aluminum alloy pistons, cast alloy cam cover • Plenty of pep for stop-and-go city driving • Sufficient power for freeway cruising.

LUV Uses Unleaded Fuel

- Contributes to longer spark plug life.
- Helps minimize lubrication system contamination.
- Extends oil change intervals and life of oil filter.
- "Unleaded Fuel" labels on instrument panel and LUV exterior at filler neck.

Electric Fuel Pump

- Improves hot fuel and hot weather starting.
- Eliminates vapor lock.

Automatic Choke

- Better response in cold weather starting.

Electrical system completely fused

- Transparent cover on terminal box, located in engine compartment for easy access • Color-coded wiring for easy servicing.

Clutch • Single plate 7.87" diameter with woven facing material • Hydraulically-operated clutch release for driver comfort.

4-speed manual transmission standard

- Fully synchronized forward gears.
- New automatic transmission available.

Fuel tank capacity approximately 13 gallons.

Body-on-frame construction • Comfortable ride

- Separate cab and pickup box • Ladder-type frame with six crossmembers • Rubber body mounts absorb road vibration.

Steering system is recirculating ball design

- 17.8:1 overall steering ratio for quick response
- Turning diameter, 36.2 feet • Good maneuverability in tight situations, and easier parking • 15.7-inch steering wheel, two-spoke design with horn button.

Tough Chassis

- Ladder-type frame.
- Box section steel side rails.
- Six sturdy crossmembers.

All-Steel Cab

- Bolted to frame on rubber biscuit-type mounts.
- Insulates cab from noise and vibrations.

Original equipment tires now include domestic brand names • Five tubeless E78 x 14B (4PR) blackwalls • Wheels painted white • Hubcaps standard.

CHEVROLET LUV CHASSIS FEATURES

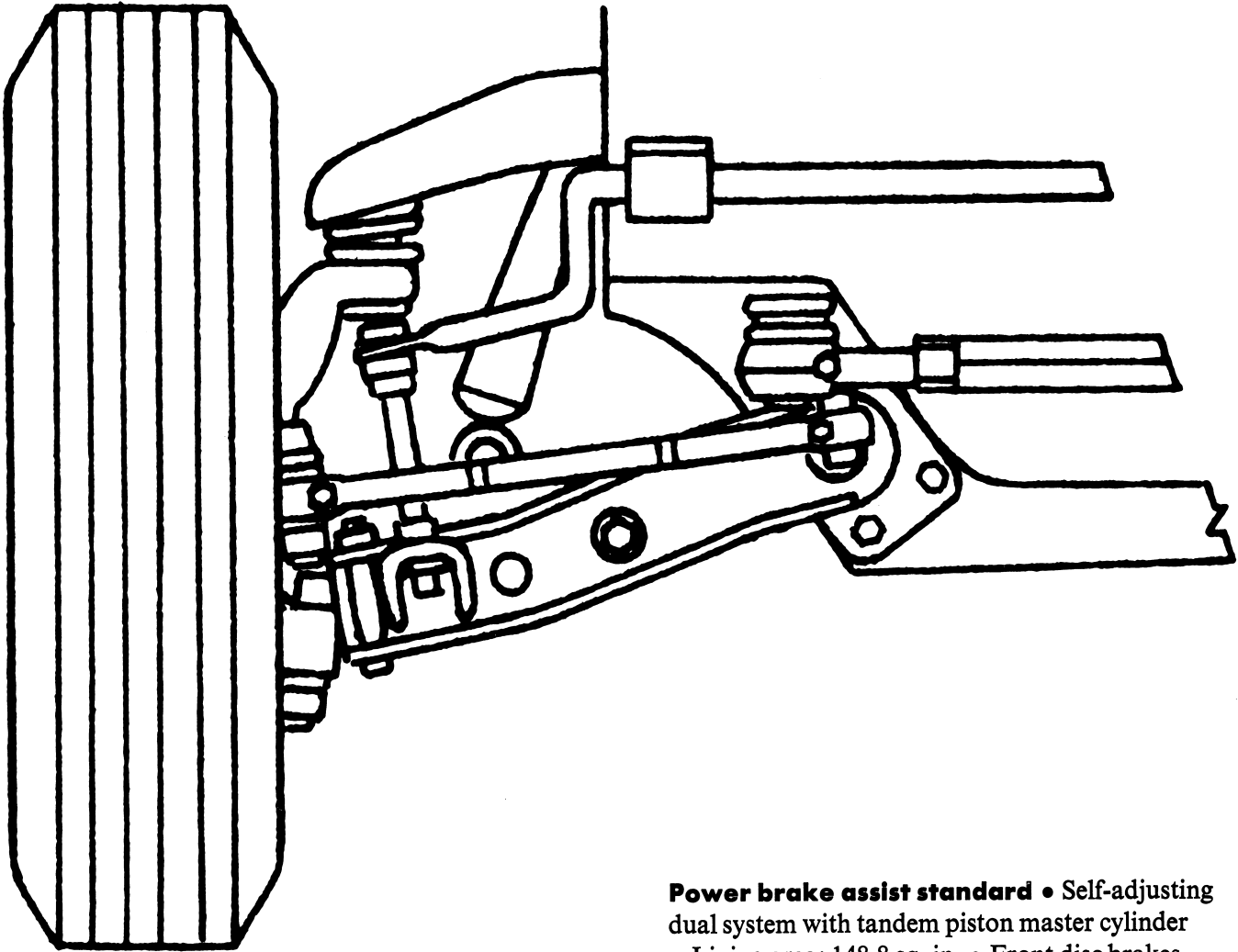

Front suspension features independent torsion bar springs • 1" diameter shock absorbers standard • Front stabilizer bar standard • Improves lateral stability.

Rear suspension springs composed of four semi-elliptic main leaves plus a short tapered helper leaf. • Variable rate helps compensate for different cargo weights • Cab and body mounts and rear suspension bushings and shackles have been redesigned to smooth the ride • Lower rear vehicle trim height • 1" diameter shock absorbers standard.

Power brake assist standard • Self-adjusting dual system with tandem piston master cylinder • Lining area: 148.8 sq. in. • Front disc brakes • Self-adjusting • Molded linings bonded to rear brake shoes.

Parking brake • Manually operated • Actuates rear service brakes • Ratchet type L-handle located below dash panel to right of steering column.

Rear axle • Semi-floating type with banjo housing • Hypoid ring gear • Axle ratio: 4.10 to 1.0 • Rated capacity: 3,500 lbs.

Exhaust system • Exhaust system components are steel with zinc outer plating • Resists corrosion.

CHEVROLET LUV POPULAR OPTIONS



Full-Width One-Piece Chrome Rear Bumper

Improves appearance • Increases rear vehicle protection.

Front bumper guards

Chromed • Improve appearance • Provide additional grille protection against bumper override.

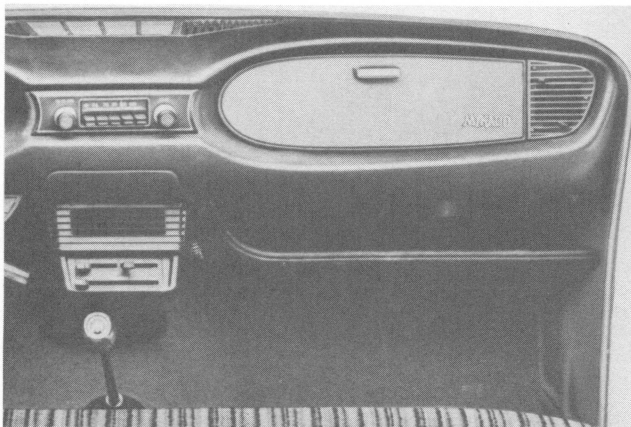

Air Conditioning

Factory-engineered for LUV • Cools cab for year-around comfort • Neatly built in, not added on later
• Includes 40-amp alternator.

Rear Step Bumper

Convenient access to cargo • Hole for attachment of trailer hitch ball.

AM or AM/FM Radio

Pushbutton tuning • Good sensitivity.

Whitewall Tires

Tubeless nylon E78 x 14B (4PR)

Basic Decor Package

- Bright belt line moldings.
- Roof drip moldings.
- Windshield molding.
- Full chrome wheel covers.

Automatic transmission

3-speed Turbo Hydra-matic • Model THM-200
• Designed by General Motors • T-handle selector, pedestal-mounted on the floor • Adds driver convenience and comfort.

CHEVROLET LUV DEALER-INSTALLED ACCESSORIES



Accessories available from Chevrolet for dealer installation. Accessory part number also shown:

- Right-hand outside rearview mirror (995162).
- Rear step bumper (994824).
- Front bumper guards (994873).
- Below Eyeline mirrors (994661).
- Sliding rear window (994554).
- AM/FM radio (994565).
- AM/FM radio antenna (994561).
- Mud flaps (94021668).
- Wheel covers (94023359).
- Door edge guards (994919).

Accessories illustrated are dealer-installed.

CHEVROLET LUV STANDARD INTERIOR

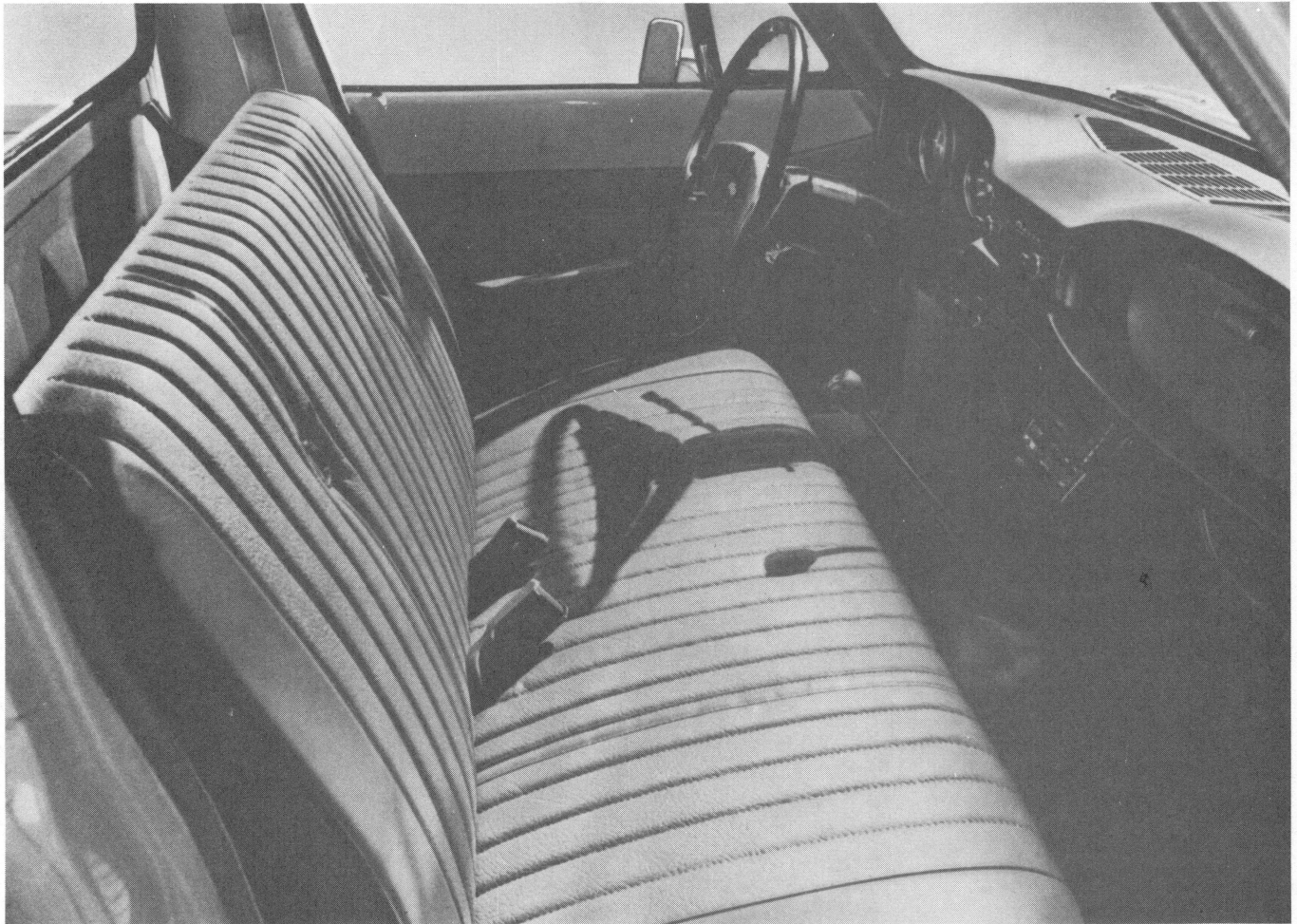

- Color-keyed ashtray includes cigar lighter.
- Embossed vinyl door trim panels.
- Dome lamp.
- Color-keyed molded vinyl floor mats.
- Instruments: Gauges: speedometer, odometer, temperature and fuel. Plus warning lights.
- Graphic control identification.
- Foam-padded, vinyl-coated instrument panel.
- Vinyl color-keyed headliners.
- Interior lights.
- Insulation and sound deadening material.
- Inside-mounted rearview mirror.
- Seat and shoulder belts.
- LH and RH, vinyl-trimmed, color-keyed sunshades.
- Glove box and package tray.
- Full-width vinyl-covered bench seat.
- Fresh air heater /defroster.
- Full-view rear cab window.

Steering column lever combines directional signal and dimmer switch • Up and down operates turn signals • Fore and aft controls high and low headlamp beams.

Convenient storage area behind full-width tilting seat backrest stows jack • Holds small items or packages hidden from outside view.

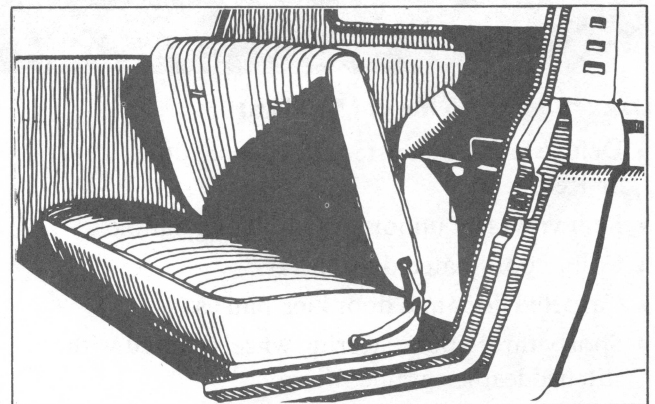

CHEVROLET LUV MIKADO INTERIOR FEATURES



Luxury Mikado Model Option:

- Deluxe fabric upholstery in Blue, Saddle or Red.
- Knit vinyl seat upholstery in Blue or Saddle.
- Color coordinated door inserts.
- Carpeted floor and door kick panels.
- Sporty three-spoke steering wheel covered with stitched leather-grained vinyl.

(Deluxe fabric shown)

- Leather-grained-vinyl-covered gearshift knob.
- Deluxe door-operated dome lamp.
- Ashtray lamp.
- Dual-note horn.
- Mikado nameplates on glove box door and rear fender panels.

CHEVROLET LUV VALUE FEATURES

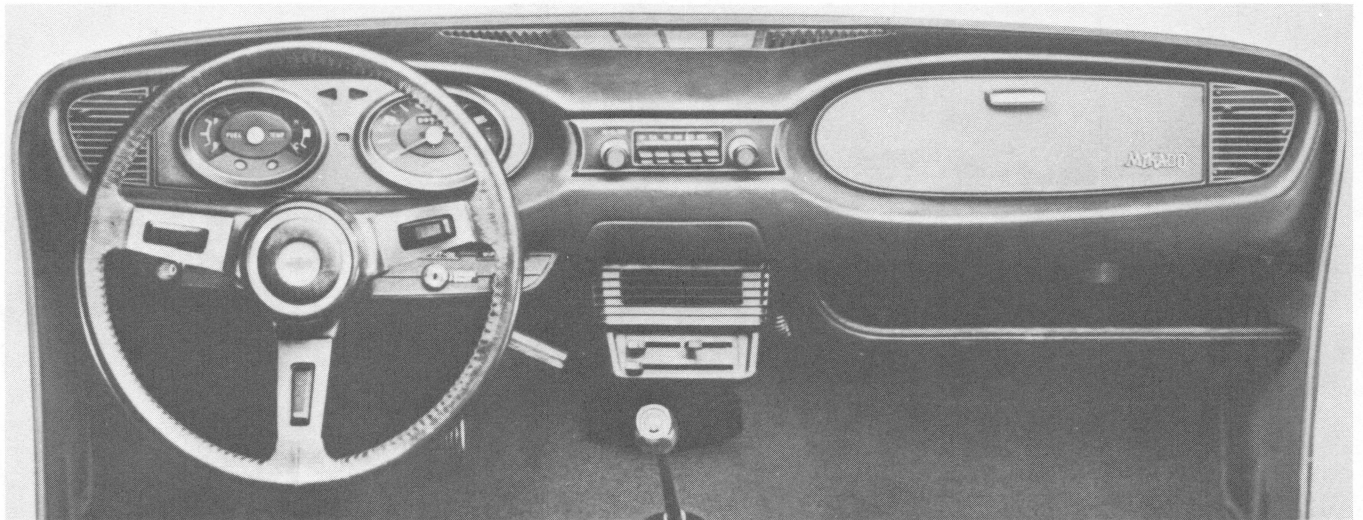

Full-width instrument panel pad reduces glare
• Glove box and storage compartment underneath (except with air conditioning) • Cigar lighter.

(Mikado option interior shown)

Fresh-air heater defroster with four-speed blower standard • Five vent openings.

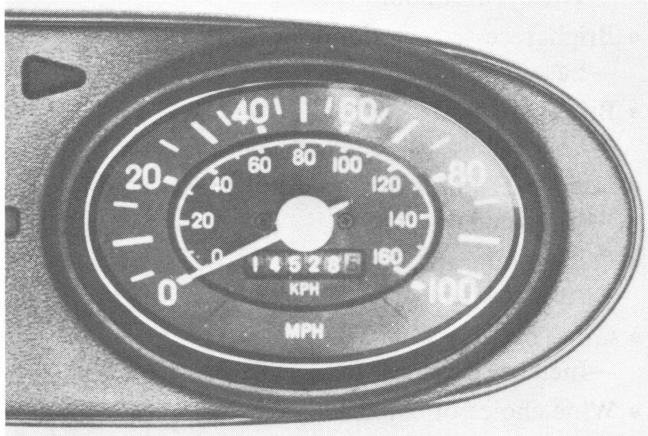

Speedometer • Calibrated to read both miles and kilometers per hour • Odometer included — records miles traveled.

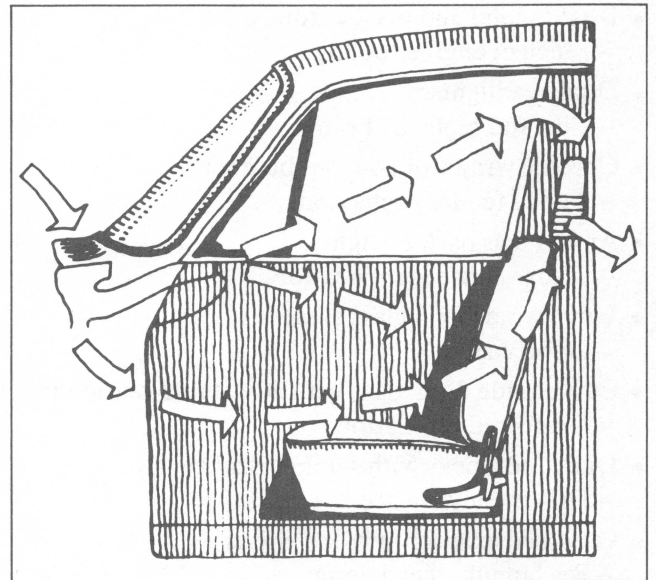

Flow-through cab ventilation • High- and low-level outlets • Adjustable vents on each side of instrument panel • Exhaust louvers in upper rear quarter panels • Fan supplies outside air continuously with ignition on.

CHEVROLET LUV VALUE FEATURES



All this included as standard equipment:

- Bright metal and plastic front grille.
 - Efficient engine cooling.
- Dual headlights.
 - City and highway beams.
- Chrome wraparound front bumper.
 - Added fender protection.
- Amber lens parking lights.
 - Clear vehicle identification.
- Large windshield glass area.
 - Good visibility.
- Curved side door glass with adjustable ventipane.
 - Draft-free ventilation.
- Dual door locks with symmetrical keys.
 - Driver convenience.
- Chromed exterior mirror—driver's side.
 - Rectangular head design.
- Dual windshield wipers and washer.
 - Large wiped area.
- Front-hinged hood.
 - Easy access for maintenance.
- Inside hood release.
 - Theft prevention.
- Bright recessed exterior door handles.
 - Ease of operation.
- Bright fuel tank filler cap.
 - Easy to locate in body side.
- High-level air intake flow-through ventilation.
 - Good cab ventilation.
- Painted hubcaps.
 - Accent wheel styling.
- Gross payload 1490 lbs.
 - Includes driver, passenger, accessories, cargo.
- Wide choice of colors.
 - Six exterior colors.

CHEVROLET LUV VALUE FEATURES



Smart Rear-End Styling

- Taillight design integrated into corner posts.
- Taillights visible even with gate down.
- Good rear visibility when towing.
- Lexan® (impact-resistant) lenses in taillights.

Full-width tailgate, bottom hinged and side latched

- “Grain-tight” tailgate seal
- Rubber damped anti-rattle links instead of chains
- Inner panel integral part of tailgate assembly
- Close tailgate-to-floor clearance with gate open flat.

All-steel welded pickup box • 6-foot nominal length, internal wheelhouses • Capacity of approximately 38 cubic feet • Integral skid strips • Eleven cargo hold-down eyes.

Spare tire stowed underneath cargo box • Crank inserted from the back raises and lowers spare by chain and winch.

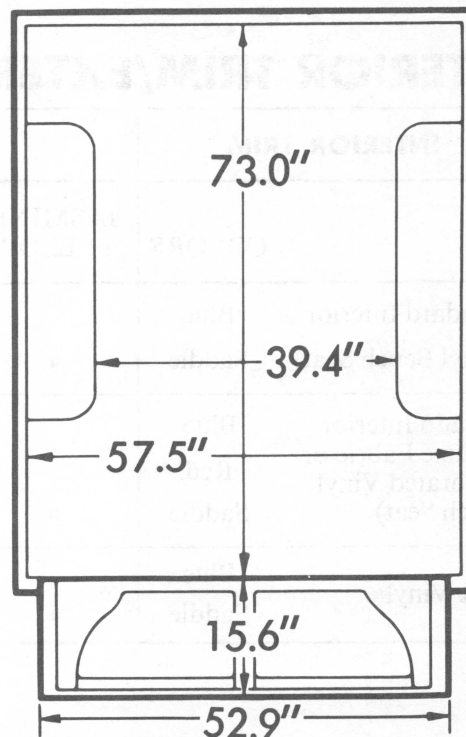

CHEVROLET LUV SERIES 5—STANDARD SPECIFICATIONS

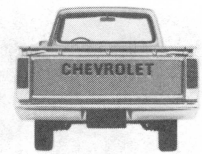
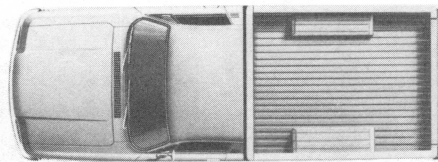
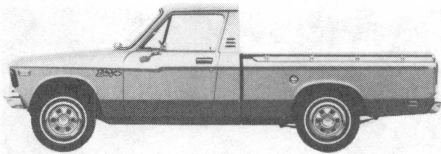

Specifications

Engine

Displacement—110.8 cu. in.
Bore x Stroke—3.31 x 3.23
Net HP (SAE)—80 @ 4800
Net torque (SAE)—95 @ 3000
Comp. ratio—8.5:1
Automatic choke

Front Suspension

Independent torsion spring
Stabilizer—Standard
Shock absorbers—1" diameter

Rear Suspension

Hypoid, leaf spring
Axle capacity—3500 lbs.
Ratio—4.10
Springs—2-stage
Shock absorbers—1" diameter

Brakes

Front—disc, Rear—drum
Master cylinder—Tandem piston
Power assist—Standard
Parking—Cable

Electrical

12-volt
Battery—50-amp
Alternator—35-amp

Frame

Ladder-type

Fuel Tank

13 gallons
Pump—Electric

Steering

Recirculating ball
Turning diameter—36.2 feet

Transmission

4-Speed
Type—Fully synchronized

Tires (5)

E78 x 14B (4PR)
Type—Tubeless

Spare Tire Carrier

Winch /Chain Unit under pickup box

Weights

GVW rating—3950 lbs.
Curb weight—2460 lbs.
Passenger weight (2)—300 lbs.
Accessories—80 lbs.
Net payload—1190 lbs.
Gross payload*—1490 lbs.

***Includes driver, passenger, cargo and equipment.**

INTERIOR TRIM/EXTERIOR COLOR COMBINATIONS

INTERIOR TRIM		EXTERIOR COLORS					
COLORS		JASMINE YELLOW	STRATO WHITE	CRIMSON RED	SHANNON GREEN	SKY BLUE	DESERT TAN
Standard Interior (Vinyl Bench Seat)	Blue		•			•	
	Saddle	•	•	•	•		•
Mikado Interior (Deluxe Fabric or Perforated Vinyl Bench Seat)	Blue		•			•	
	Red			•			
	Saddle	•	•		•		•
Knit Vinyl	Blue		•			•	
	Saddle	•	•	•	•		•